

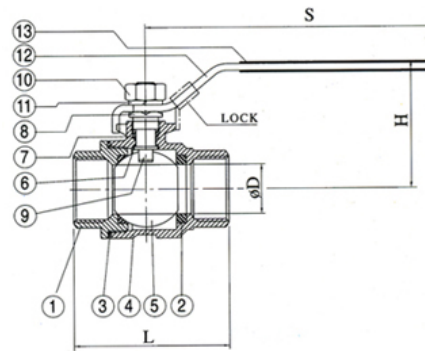

Válvula Bola NPT  
2 cuerpos 1000 PSI

cod.



**Threaded:** NPT DIN 2999  
**Materials:** CF8M (SS316)  
DIN 1.4408

**Features:**

- Investment Casting Body and Cap
- Working Pressure 1000 PSI For W.O.G.
- Adjustable Stem packing
- Pure Teflon Seals and Seats
- Temperature Range: -60to 450° F
- Blow - Out Proof Stem
- 100% Leakage Tested At 100 PSI Air Under Water
- Hydrostatic Test Pressure: 1500PSI
- Locking Device (Opcion)

**MATERIAL LIST**

NO.	PARTS NAME	MATERIAL	Q'TY
1	CAP	CF8M	1
2	BALL SEAT	PTFE	2
3	JOINT GASKET	PTFE	1
4	BODY	CF8M	1
5	BALL	316/304	1
6	THRUST WASHER	PTFE	1
7	STEM PACKING	PTFE	1
8	GLAND NUT	304	1
9	STEM	316	1
10	STEM NUT	304	1
11	SPRING WASHER	304	1
12	HANDLE	304	1
13	PLASTIC SLEEVE	PVC	1

**DIMENSIONS**

UNIT: mm

ITEM MEDIDAS	1/4"	3/8"	1/2"	3/4"	1"	1 1/4"	1 1/2"	2"	2 1/2"	3"
OD	11.6	11.6	15.0	20.0	25.0	32.0	38.0	50.0	64	76
L> + 2	54	54	64	74	87	101	110	132	165	187
S+3	104	104	104	123	154	154	189	189	244	244
H+3	50	50	52	62	75	81	90	98	139	148
W	10-24 UNC	10-24 UNC	10-24 UNC	10-24 UNC	10-24 UNC	1/4-20 UNC	1/4-20 UNC	1/4-20 UNC	1/4-20 UNC	1/4-20 UNC



**ALLEN**  
Aceros Inoxidables